

CM40 – 125A POMPĂ CENTRIFUGALĂ

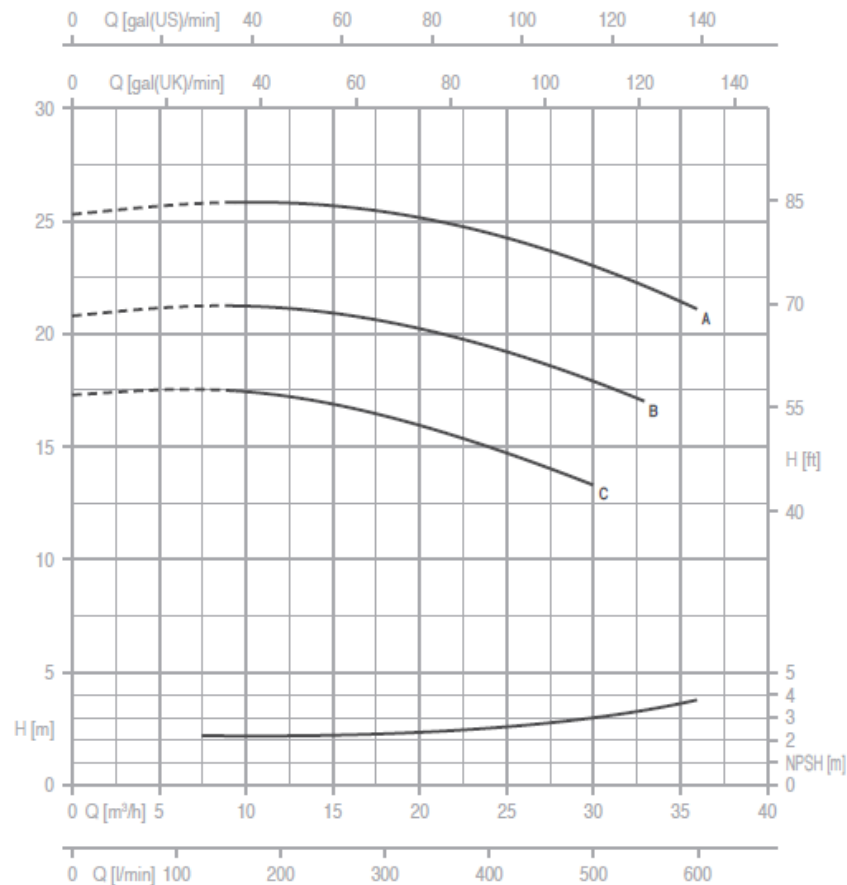

Putere absorbită P1:	4.1 kW
Putere P2:	3.0 kW
Alimentare:	400 V / 50 Hz
Inălțime maximă de refulare:	25.8 m
Debit maxim:	3600 l/h
Diametru de aspirație:	65 mm
Diametru de refulare:	40 mm



Debit Q (m ³ /h – l/min)										
0	9	12	15	18	21	24	27	30	33	36
0	150	200	250	300	350	400	450	500	550	600
Înălțime de refulare H (m)										
25.2	25.8	25.8	25.6	25.4	24.9	24.4	23.7	22.9	22	21.1

Temperatura maximă a apei:
 Carcasă pompă:
 Suport motor:
 Rotor pompă:
 Etanșare mecanică:
 Arbore motor:
 Clasă de izolație:
 Clasă de protecție:
 Flanșe de cuplare pentru aspirație
 și refulare:

90 °C
 fontă
 fontă
 fontă
 ceramică – grafit
 oțel AISI 304
 F
 IP55

 incluse

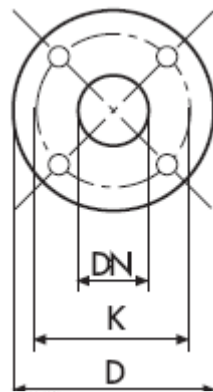

DIMENSIONS (mm)				
DN	D	K	holes	
			n°	ø
32	140	100	4	18
40	150	110	4	18
50	165	125	4	18
65	185	145	4	18
80	200	160	4	18
100	220	180	8	18

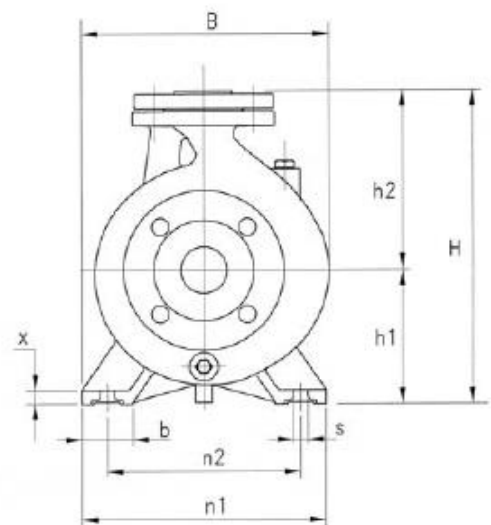
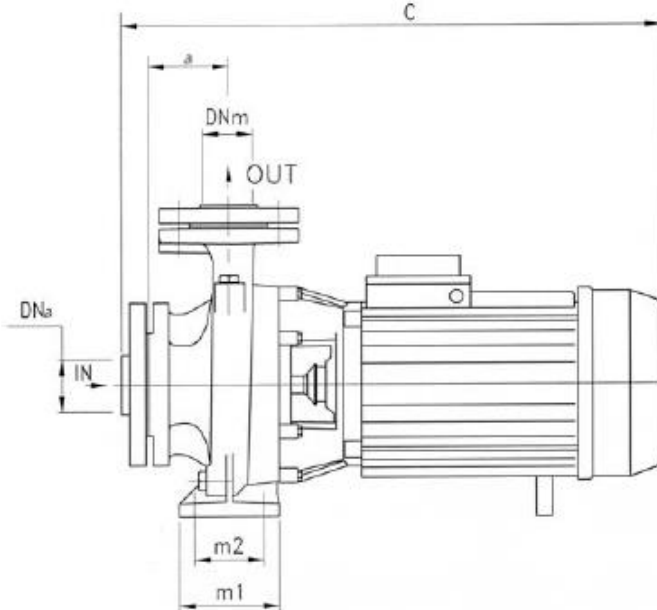

TYPE	DIMENSIONS (mm)																		Kg
	DNm	DNa	a	h1	h2	m1	m2	n1	n2	b	x	s	C	B	H	I	L	M	
CM 32-160 C	32	50	80	132	160	100	70	240	190	50	12	14	490	240	292	520	260	355	38
CM 32-160 B	32	50	80	132	160	100	70	240	190	50	12	14	490	240	292	520	260	355	39
CM 32-160 A	32	50	80	132	160	100	70	240	190	50	12	14	490	240	292	520	260	355	42
CM 32-200 C	32	50	80	160	180	100	70	240	190	50	12	14	505	268	340	530	305	400	51.5
CM 32-200 B1	32	50	80	160	180	100	70	240	190	50	12	14	520	268	340	615	310	460	61
CM 32-200 B	32	50	80	160	180	100	70	240	190	50	12	14	565	268	340	615	310	460	63
CM 32-200 A1	32	50	80	160	180	100	70	240	190	50	12	14	520	268	340	615	310	460	67
CM 32-200 A	32	50	80	160	180	100	70	240	190	50	12	14	565	268	340	615	310	460	69
CM 32-250 C	32	50	100	180	225	125	95	320	250	65	12	14	625	305	405	665	335	535	83
CM 32-250 B	32	50	100	180	225	125	95	320	250	65	14	14	625	305	405	665	335	535	90
CM 32-250 A1	32	50	100	180	225	125	95	320	250	65	14	14	625	305	405	665	335	535	96
CM 32-250 A	32	50	100	180	225	125	95	320	250	65	14	14	695	305	405	735	335	535	120
CM 40-125 C	40	65	80	112	140	100	70	210	160	50	12	14	495	220	252	520	260	355	36
CM 40-125 B	40	65	80	112	140	100	70	210	160	50	12	14	495	220	252	520	260	355	37
CM 40-125 A	40	65	80	112	140	100	70	210	160	50	12	14	495	220	252	520	260	355	40
CM 40-160 B	40	65	80	132	160	100	70	240	190	50	12	14	500	245	292	520	260	355	47
CM 40-160 A	40	65	80	132	160	100	70	240	190	50	15	14	500	245	292	520	260	355	50
CM 40-200 B	40	65	100	160	180	100	70	265	212	50	15	14	590	273	340	615	310	460	65
CM 40-200 A	40	65	100	160	180	100	70	265	212	50	15	14	590	273	340	615	310	460	71
CM 40-250 C	40	65	100	180	225	125	95	320	250	65	15	14	630	322	405	665	335	535	84
CM 40-250 B	40	65	100	180	225	125	95	320	250	65	15	14	630	322	405	665	335	535	91
CM 40-250 A1	40	65	100	180	225	125	95	320	250	65	15	14	630	322	405	665	335	535	96
CM 40-250 A	40	65	100	180	225	125	95	320	250	65	15	14	700	322	405	735	335	535	121